

Section
5

THE ROBOT



Table of Contents

5 THE ROBOT	2
5.1 OVERVIEW	2
5.1.1 What is a FIRST Robot?	2
5.1.2 Getting Started	2
5.1.3 Related Documents & Resources	3
5.1.4 Conventions	3
5.2 DEFINITIONS	3
5.3 ROBOT RULES	5
5.3.1 General Design & Safety Rules	6
5.3.2 Robot Physical Rules	6
5.3.3 Fabrication Schedule	8
5.3.4 Robot Material Utilization Rules	9
5.3.5 Electrical System Rules	16
5.3.6 Custom Circuit Rules	17
5.3.7 Control System Rules	17
5.3.8 Operator Interface Rules	18
5.3.9 Wiring Rules	19
5.3.10 Pneumatic System Rules	20
5.3.11 Non-Functional Decoration Rules	21
5.3.12 Robot Inspection Rules	22
5.4 KIT OF PARTS	23
5.4.1 2006 Kit Changes	23
5.4.2 Kit Of Parts Contents	23
5.4.3 Replacement Parts Requests	29
5.4.4 Innovation First Kit of Parts:	30
5.4.5 Obtaining Replacement or Spare Parts:	30
5.4.6 FIRST Loan policy for Control System Components:	30

5 THE ROBOT

5.1 OVERVIEW

This section of the 2006 FIRST Robotics Competition Manual provides:

- NEW Rules applicable to the design and construction of the 2006 Robot.
- Descriptions of NEW mechanical and electrical systems that are based on parts provided in the 2006 Kit of Parts (KOP).

Information about the Vision system, Transmission kit, and Chassis kit, is included in this chapter and is also available from the device manuals and specification sheets.

COMPLIANCE WITH ALL RULES IS MANDATORY.

Robots will be inspected at each FIRST event to verify rules compliance before being allowed to compete.

5.1.1 What is a FIRST Robot?

A FIRST robot is a remotely operated vehicle designed and built by a FIRST Robotic Competition team to perform specific tasks when competing in the 2006 competition “Aim High.”

5.1.2 Getting Started

Please be sure to thoroughly read and understand Sections 3, 4, 5, and 8 of this manual before designing your robot. In particular, pay attention to *Section 5.3.1. General Design & Safety Rules* and *Section 5.3 Robot Rules* before proceeding. The following are just a few important points offered to help teams in getting started:

1. Evaluate the Game's physical challenges and identify those that the robot will have to overcome.
 - Will it have to climb structures, pick and place items, push / pull goals, possess a low profile, extend its height, lift items, hang, etc.?
 - What are the game's implications regarding the robot's center of gravity?
 - Are unique field surface characteristics important when determining robot driving mechanism tread design?
 - Are there any particular offensive / defensive capabilities important to the robot?
2. Inspect all items provided in the Kit of Parts (see Section 5.4) and review their basic features. Note that suppliers' data sheets are referenced in the Part Kit tables for many of the components in the Kit.
3. We recommend that you carefully read the manuals and documents listed in *Section 5.1.3 Related Documents & Resources*.
4. Look over the specifications and technical notes provided for the various Kit components.
5. Note all Safety Rules relating to the robot's design. They include:
 - The locations and ratings of circuit breakers where indicated in the wiring diagrams
 - Wire size
 - Stored energy guidelines
 - Attention to sharp corners and edges
 - Shields for moving parts and pinch points

5.1.3 Related Documents & Resources

In addition to this chapter, other sections in this manual and other documents should be reviewed before proceeding with the robot design process:

- **Section 3: The Arena, Section 4: The Game** and **Section 8: The Tournament**
- **Section 6.5.1.1 Crate Shipping Deadlines** as listed in **Section 6: Robot Transportation**
- Innovation First, Inc. instruction manuals for the *Robot Controller*, *Spike Relay modules*, and *Victor 884 Speed Controllers* as provided by their manufacturer
- FIRST 2006 Transmission Manual
- FIRST 2006 Chassis Kit Manual – Information to assemble Chassis Kit and Drive Train available at: <http://www.ifrobotics.com/kitbot.shtml>.

Important FIRST Manuals, Drawings, available at http://www.usfirst.org/robotics/doc_updt.htm include:

- FIRST 2006 Software Quick Start Guide – A guide to software tools available for robot and vision system programming
- 2006 CMUCam2 Engineering Workbook – A guide to vision system programming using Labview8 and EasyC software applications.
- FIRST 2006 Pneumatics Manual - Valuable information about the pneumatic components and ordering processes are included.
- 2006 Robot Power Distribution Diagram

5.1.4 Conventions

Specific methods are used throughout this section to highlight Warnings, Cautions, key words or phrases to alert the reader to important information designed to help teams in constructing a robot complying with the Rules in a safe and workmanlike manner.

Warnings, Cautions, and Notes appear in bordered boxes. Key words, Phrases, or References appear in bold italics such as a ***Section Number*** reference. Operating keys, controls, buttons appear in bold capital letters (i.e. **OFF/ON** switch or **RESET** button).

This section includes hypertext. Clicking on the Underlined Italic text will link you to additional information related to that item or subject.

5.2 DEFINITIONS

COMPONENT – A robot part in its most basic configuration, which cannot be disassembled without damaging or destroying the part, or altering its fundamental function.

- Example 1: raw aluminum stock, pieces of steel, wood, etc., cut to the final dimensions in which they will be used on the robot, would all be considered components. Bolting pieces of extruded aluminum together as a robot frame would constitute a **MECHANISM**, and the collection of pieces would not be considered a **COMPONENT**.
- Example 2: a COTS (See immediately below) circuit board is used to interface to a sensor on the robot, and it includes the circuit board and several electrical elements soldered to the board. The board is considered a **COMPONENT**, as this is the basic form in which it was purchased from the vendor, and removing any of the electrical elements would destroy the functionality of the board.

COTS – A “Commercial, Off-The-Shelf” **COMPONENT** or **MECHANISM**, in its unaltered, unmodified state. A COTS item must be a standard (i.e. not custom order) part commonly available from the **VENDOR**, available from a non-team source, and available to all teams for purchase.

- Example 1: a team orders two robot grippers from RoboHands Corp. and receives both items. They put one on their store room and plan to use it later. Into the other, they drill “lightening holes” to reduce weight. The first gripper is still classified as a COTS item, but the second gripper is now a “custom part” as it has been modified.
- Example 2: a team obtains openly-available blueprints of a drive component commonly available from Wheels-R-U's Inc. and has local machine shop “We-Make-It, Inc.” manufacture a copy of the part for them. The produced part is NOT a COTS item, because it is not commonly carried as part of the standard stock of We-Make-It, Inc.

FABRICATED ITEM – Any COMPONENT or MECHANISM that has been altered, built, cast, constructed, concocted, created, cut, heat treated, machined, manufactured, modified, painted, produced, surface coated, or conjured into the final form in which it will be used on the robot.

- Example 1: A piece of extruded aluminum has been ordered by the team, and arrives in a 20-foot length. To make it fit in their storage room, the team cuts it into two ten-foot lengths. These would not be considered FABRICATED ITEMS, as they have not been cut to the final length in which they will be used on the robot.
- Example 2: A team has designed an arm mechanism that uses gears with a 1/2-inch face width. They order a 12-inch length of gear stock and cuts it into precise 1/2 inch slices. They have not yet bored out the mounting bores in the center of the gears. The slices are now considered FABRICATED ITEMS, as they have been cut to final size, even though all the machining operations (the center bore) may not yet be completed.

FIX-IT-WINDOWS – Two 5-hour work periods following the deadline for shipping the robot, or following the close of a regional competition, in which ALL teams may manufacture parts in preparation for future competitions. During the FIX-IT WINDOWS, software for either the robot or operator interface may be developed without restriction. The FIX-IT WINDOWS are limited to single continuous time periods with a maximum duration of 5 hours each. Part or all of the team may participate in the work conducted during this period. The FIX-IT WINDOWS may not be subdivided into multiple work sessions of lesser duration.

MECHANISM – A COTS or custom assembly of COMPONENTS that provide specific functionality on the robot. A MECHANISM can be disassembled (and then reassembled) into individual COMPONENTS without damage to the parts.

SPARE PARTS – A COMPONENT or MECHANISM constructed as an identical duplicate of an existing part of the robot, for the purpose of replacing a broken or defective part. SPARE PARTS may be either COTS items or FABRICATED ITEMS, but they must be physically and functionally identical to the original part.

REPLACEMENT PARTS – A COMPONENT or MECHANISM constructed as a functional duplicate of an existing part of the robot, for the purpose of replacing a broken or defective part. REPLACEMENT PARTS may be either COTS items or FABRICATED ITEMS. They must be functionally identical to the original part but may be modified to provide more robust performance of the function.

- Example 1: A lever arm made of lexan on your robot breaks. You manufacture a REPLACEMENT PART made of aluminum plate, using the design drawings of the original. As the new part provides the same function as the broken part, the new part is a valid REPLACEMENT PART.
- Example 2: A sensor on the robot is connected to the control system with 24gauge single-strand wire, and runs across a hinged joint. The flexing of the wire causes it to break, and you want to replace it with 18-gauge multi-strand wire. If the new wire follows the same path as the original and connects only the same devices, then it is a valid REPLACEMENT PART (i.e. it has added robustness without changing function). But if the wire is then used to connect an additional sensor to the same circuit, it is providing a functionally different capability, and is no longer a “replacement.”

UPGRADE PARTS - A COMPONENT or MECHANISM intended to provide additional functionality not currently available on the robot. UPGRADE PARTS may be COTS items or custom FABRICATED ITEMS, and may either add to or replace existing functionality.

- Example 1: A robot is designed with a four-wheel drive system. The system works well on flat floors, but high-centers when trying to drive up steps. The team adds two more wheels on the centerline of the robot to prevent this problem, and the wheels are identical to those already on the robot. The new wheels would be considered UPGRADE PARTS even though they are the same as the ones already in place, as they alter the functionality of the robot and provide new capability.

VENDOR – A legitimate business source for COTS items that, as a minimum, satisfies the following criteria:

- The VENDOR must have a Federal Tax Identification number.
 - The Federal Tax Identification number establishes the VENDOR as a legal business entity with the IRS, and validates their status as a legitimate business.
- The VENDOR must be normally able to ship any general (i.e., non-FIRST unique) product within five business days of receiving a valid purchase request. It is recognized that certain unusual circumstances, such as 1,000 FIRST teams all ordering the same part at once from the same VENDOR, may cause atypical delays in shipping due to backorders for even the largest VENDORS. Such delays due to higher-than-normal order rates are excused.
 - The FIRST Robotics Competition build season is only six weeks long, so the VENDOR must be able to get their product, particularly FIRST unique items, to a team in a timely manner.
- The business should maintain sufficient stock or production capability to fill teams orders within a reasonable period during the build season (<1 week). Note that this criterion may not apply to custom-built items from a source that is both a VENDOR and a fabricator. For example, a VENDOR may sell flexible belting that the team wishes to procure to use as treads on their drive system. The VENDOR cuts the belting to a custom length from standard shelf stock that is typically available, welds it into a loop to make a tread, and ships it to a team. The fabrication of the tread takes the VENDOR two weeks. This would be considered a FABRICATED ITEM, and the two weeks ship time is acceptable. Alternately, the team may decide to fabricate the treads themselves. To satisfy this criterion, the VENDOR would just have to ship a length of belting from shelf stock (i.e. a COTS item) to the team within five business days and leave the welding of the cuts to the team.
- The VENDOR makes their products available to all FIRST Robotics Competition teams.
- VENDORS must not limit supply or make a product available to just a limited number of FIRST Robotics Competition teams.
- Ideally, chosen VENDORS should have national distributors.
 - Example distributors include Home Depot, Lowes, MSC, Radio Shack, and McMaster-Carr. FIRST competition events are not usually near home. When parts fail, local access to replacements is often critical.

FIRST desires to permit teams to have the broadest choice of legitimate sources possible, and to obtain COTS items from the sources that provide them with the best prices and level of service available. The intent of this definition is to be as inclusive as possible to permit access to all legitimate sources, while preventing *ad hoc* organizations from providing special-purpose products to a limited subset of teams in an attempt to circumvent the cost accounting rules.

5.3 ROBOT RULES

These Rules establish the global robot construction and performance constraints dictated by the characteristics of the provided Kit of Parts along with the size and weight design limits specified in this section. **Compliance with the Rules is Mandatory. Any Robot construction not in compliance with the Rules (determined at inspection) must be rectified before a robot will be allowed to compete.**

When reading these Rules, please use technical common sense (engineering thinking) rather than a lawyer's interpretation. Try to understand the reasoning behind a rule.

5.3.1 General Design & Safety Rules

<R01> Each team may enter ONE robot into the 2006 FIRST Robotics Competition. That robot must be assembled using materials from the 2006 FIRST Kit of Parts, and other allowed materials as specified in the Rules, and must fully comply with all Rules.

<R02> Energy used by FIRST Robotics Competition robots, (i.e., stored at the start of a match), may only come from the following sources:

- Electrical energy derived from the onboard 12V and 7.2V batteries
- Compressed air stored in the pneumatic system, but only supplied by the compressor included in the kit, and stored at a maximum pressure of 120 PSI in no more than two Clippard Instruments tanks.
- A change in the altitude of the robot's center of gravity.
- Storage achieved by deformation of robot parts. Teams must be very careful when incorporating springs or other items to store energy on their robot by means of part or material deformation. A robot may be rejected at inspection if, in the judgment of the inspector, such items are unsafe.

<R03> Protrusions from the robot must not pose hazards or be dangerous to team members or event staff. If, in the judgment of the inspectors or referees, a device on the robot poses a hazard (particularly puncture or impalement hazards) then the team will be required to remedy the situation before the robot will be allowed to play. If the robot includes protrusions that form the "leading edge" of the robot as it drives, and are less than one square inch in surface area, it will invite detailed inspection. For example, forklifts, lifting arms, grapples, etc. may be carefully inspected for these hazards.

<R04> "Wedge" robots are not allowed. Robots must be designed so that interaction with other robots results in pushing rather than tipping or lifting. Neither offensive nor defensive wedges are allowed. All parts of a robot between 0 and 8.5 inches from the ground (the top of the bumper zone – see Rule <R35>) that might push against another robot must be within 10 degrees of vertical. Devices deployed outside the robot's footprint should be designed to avoid wedging. If a mechanism or an appendage (a ball harvester, for example) becomes a wedge that interferes with other robots, penalties, disabling, or disqualification can occur depending on the severity of the infraction.

5.3.2 Robot Physical Rules

5.3.2.1 Robot Size

<R05> At the beginning of the match, the *maximum allowed size of the robot* is 28 inches (71.12cm) by 38 inches (96.52cm) by 60 inches (152.40cm) tall.

<R06> The starting configuration of a robot immediately prior to being enabled by the Arena Controller at the beginning of a match is the basis upon which a robot will be inspected for compliance with the maximum allowed size. This configuration of the robot must fit within a FIRST Sizing Device that has the following inside surface dimensions: a flat, level rectangular base 28 inches x 38 inches, and a height of 60 inches. Other than resting on the floor of the Sizing Device, no part of the robot may break the plane of the sides or top of the Sizing Device during size inspection. The robot must be self-supporting while in the Sizing Device.

<R07> If a robot has been designed such that it may have more than one possible starting configuration, the largest possible configuration must be the one used during size inspection.

<R08> Once a match begins, robots may extend horizontally beyond the 28-inch x 38-inch starting size under their own power, up to a limit of 60 inches in either horizontal cardinal dimension. The robot may not exceed the 60-inch height restriction at any time during the match. In other words, after the start of the match the robot may expand up to a maximum volume of 60 inches by 60 inches by 60 inches. The one exception to the height restriction is provided in Rule <R13>. Any restraints (elastic bands, springs, etc.) that are used to maintain starting size must remain attached to the robot for the duration of the match.

5.3.2.2 Robot Weight

<R09> The maximum allowed weight of **all** robot configuration mechanisms combined, **not including an Exide battery and its associated half of the Anderson cable quick connect/disconnect pair, and any robot bumper assemblies** is 120 pounds (54.43 kg). At the time of weigh in, the basic robot structure and all elements of all additional mechanisms that might be used in different configurations of the robot must be weighed together. Included in the weight limit is the robot control system, back-up 7.2V battery, decorations, and any other attached parts, but not bumpers (see immediately below and Rule<R35>), the Exide 12VDC battery and its associated half of the Anderson connection pair (including no more than 12 inches of cable per leg, the associated cable lugs, connecting bolts, and insulating electrical tape)

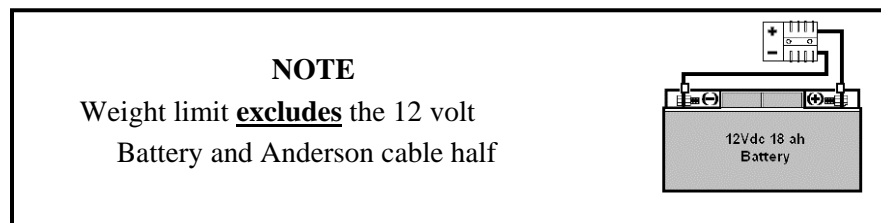

- Example: A team has decided to design its robot such that, before any given match, it may quickly change the configuration of the robot based on perceived strengths or weaknesses of an opponent team's robot. The team accomplished this by constructing its robot as a basic drive train platform plus two versions of a ball catcher, each catcher being a quick attach / detach device such that either one or the other catcher (but not both) may be part of the robot at the beginning of a match. Their robot's platform weighs 107 lb, version A of the catcher weighs 6 lb, and version B weighs 8 lb. Although only one version will be on the robot during a match, both catchers (and all components of the catchers that would be used during the match) must be on the weight scale along with the robot platform during weigh in. This would result in a **rejection** of the robot because its total weight comes to 121 lb.

<R10> The weight of any bumper assemblies included on the robot that are in compliance with Rule <R35> is excluded from the robot weight limit specified in Rule <R09>, up to a maximum of 15 pounds.

5.3.2.3 Robot Visibility

<R11> Robots must display their school name, and primary sponsor name and/or logo whenever the robot is on the field (including practice sessions). The support provided by the corporate sponsors and mentors on your team is important, and is to be acknowledged with the appropriate display of their names/logos on the exterior of the robot.

<R12> The judges, referees, and announcers must be able to easily identify robots by Team Number. Teams must display their Team Number in four locations at approximately 90-degree intervals around the side of the robot. ***The numerals must be at least 4 inches high, at least in 3/4 inch stroke width and in a contrasting color from its background.*** Team Numbers must be clearly visible from a distance of not less than 100 feet.

<R13> Robots must use one of the two colored bicycle flags provided at the event queuing location to display their alliance color (red or blue). Each robot must include a 12 inch long, 1/2" ID PVC tube, capped at the bottom, permanently mounted on the robot such that when a 3 foot long, 1/4 inch diameter flagpole is inserted the top of the flagpole is no higher than 6 feet from the ground and the top of the flagpole is at least 12 inches higher than any other point on the robot (+/- 1/2 inch). The flagpole must be mounted such that it starts the match, and remains, approximately vertical. The flagpole receptacle must be statically mounted, and not articulated or actuated.

<R14> Robots must use the Alliance Color LED provided in the Kit of Parts to display their alliance color (red or blue). The Color LED will be used by field personnel during the matches for diagnostic purposes. It must be mounted on the robot such that their displayed color is easily visible while standing in front of the robot in its' starting position. Instructions for connecting the Color LEDs are provided in the Innovation First Controller manual. The Robot Controller directly powers and controls the Team Color LEDs. The user has no control over the Team Color LEDs and no programming is required.

5.3.3 Fabrication Schedule

One of the fundamental values of FIRST is the concept of "gracious professionalism." FIRST recognizes that it is the responsibility of each team to abide by the fabrication schedule rules defined below. As compliance with these rules takes place outside of the competition venues, FIRST is not able to directly monitor compliance. We are relying upon the honor, integrity, and professional behavior of each team to recognize and abide by the fabrication schedule rules. Teams must design and construct their robot within the schedule constraints defined as follows:

<R15> Prior to the Kick-off: Before the formal start of the robot Build Season, teams are encouraged to think as much as they please about their robots. They may develop prototypes, create proof-of-concept models, and conduct design exercises. Teams may gather all the raw stock materials and COTS items they want. But absolutely no fabrication or assembly of any elements intended for the final robot is permitted prior to the Kick-off presentation. Any MECHANISMS assembled prior to the Kick-off presentation may be used for prototyping or educational purposes, but MAY NOT be used on the final ROBOT.

<R16> During the Build Season: During the period between the Kick-off and robot shipment deadline, teams are to design and fabricate all the components and mechanisms required to complete their robot. They are encouraged to use all the materials, sources and resources available to them that are in compliance with the rules of the 2006 FIRST Robotics Competition. As the robot shipment deadline approaches, all work on the robot must cease and the robot must be placed in a "hands-off" condition. The entire robot (including all FABRICATED ITEMS intended for use during the competition in alternative configurations of the robot) must be crated and out of team hands by the robot shipment deadline.

<R17> During the “FIX-IT WINDOWS” following the shipment of the robot: During this period, all teams may utilize one or two 5-hour FIX-IT-WINDOWS to manufacture SPARE and REPLACEMENT PARTS and develop software for their robot at their home facility. Fabrication of UPGRADE PARTS is not permitted during this period. The timing of these “FIX-IT WINDOWS” is at the discretion of the team, but all work must be completed by 5:00pm on the Friday following the robot shipment deadline. Teams may manufacture all the SPARE and REPLACEMENT parts they want, but the amount of parts they can bring to the competition event is limited (as specified in Rule <R29>).

<R18> Prior to the competitions: After the close of the “FIX-IT WINDOWS” and prior to the competition, the team must put down their tools, cease fabrication of robot parts, and cease all software development. Take this opportunity to rest, recover from the build season, and relax. Teams may scout other teams, gather and exchange information, develop game-playing strategies, collect raw materials, prepare tool kits, plan how to make repairs, etc. in preparation for the upcoming competitions. But no construction or fabrication of any hardware, or development of any software, is allowed.

<R19> At the competitions: Teams are allowed to repair, modify or upgrade their competition robots while participating in a competition event. To support this, teams may bring SPARE, REPLACEMENT and UPGRADE PARTS and COTS items to the competitions (within the limits specified in Rules <R28> and <R29>). Work may only be done on-site in the Pits or at any facility made available to all teams at the event (e.g., in a team’s repair trailer or a local team’s shop offered to all teams to use). Fabrication may be done when the Pit area is open for normal operations during the period starting with the opening of the Pit area on Thursday and ending at 4:00PM on Saturday. All work must be completed when the Pit area closes each evening. Parts may not be removed from the competition site and retained overnight after the Pit area closes.

<R20> During the “FIX-IT WINDOW” following each Regional Competition weekend: During this period, all teams (not just those teams attending a Regional Competition) may utilize one or two 5-hour FIX-IT-WINDOWS to manufacture SPARE, REPLACEMENT and UPGRADE PARTS and develop software for their robot at their home facility (not at the competition site). The timing of these “FIX-IT WINDOWS” is at the discretion of the team, but all work must be completed between the close of the Competition and 5:00pm on the Thursday following the Regional Competition weekend. At the conclusion of a regional competition event, teams may take a limited amount of broken or malfunctioning COMPONENTS or MECHANISMS back to their home facility to make SPARE or REPLACEMENT PARTS. The purpose of this rule is to allow teams to make critical repairs to existing parts to enable them to compete in following events. The intent of this rule is not to have teams take their entire robot back home and make large-scale revisions or upgrades to the robot. Teams may manufacture and/or repair all the parts they want, but the amount of parts they can bring to the competition event is limited (as specified in Rule <R29>).

5.3.4 Robot Material Utilization Rules

<R21> Robots entered into the 2006 FIRST Robotics Competition must be fabricated and/or assembled from COMPONENTS, MECHANISMS and COTS items that are constructed from:

- Items provided in the FIRST supplied Kit of Parts (or their exact replacement part)
- Allowed Additional Parts and Materials as defined in this section in quantities consistent with the Cost Accounting rules.

<R22> Individual COMPONENTS from robots entered in previous FIRST competitions may be used on 2006 robots **IF** they satisfy **ALL** of the rules associated with materials/parts use for the 2006 FIRST Robotics Competition.

- <R23> Teams participating in the 2006 FIRST Robotics Competition that are located outside North America may not be able to acquire the exact part (as identified by specific part numbers) or materials of the specified dimensions as defined in these rules. In such situations, international teams may submit a request for approval of nearest-equivalent parts (e.g. nearest metric equivalent, etc.) to FIRST Headquarters. FIRST will determine suitability of the part. If approved, a confirming e-mail will be sent to the team. The team must bring a copy of the e-mail to any competition event to verify that the use of an alternate part has been approved.
- <R24> Individual COMPONENTS retrieved from previous robots and used on 2006 robots must have their undepreciated cost included in the 2006 robot cost accounting, and applied to the overall cost limits.
- <R25> Motors, pumps, and, robot controllers from previous robots may not be used in addition to those provided in the 2006 kit of parts. They may be used as direct one-to-one SPARE PARTS for those provided if the provided part fails or is damaged. They may only be used if they are identical to the part being replaced (note that 2002 and 2003 Fisher-Price motors are not the same as those in the 2006 kit, and, therefore, cannot be used).
- <R26> MECHANISMS from robots entered in previous FIRST competitions may not be used.
- <R27> Only Victor 884 Speed Controllers are permitted. Victor 883 and 885 Speed Controllers may not be used.
- <R28> Teams may acquire and bring an unlimited amount of COTS items to the competitions to be used to repair and/or upgrade their robot at the competition site.
- <R29> Teams may bring a maximum of 25 pounds of custom FABRICATED ITEMS (SPARE PARTS, REPLACEMENT PARTS, and/or UPGRADE PARTS) to each competition event to be used to repair and/or upgrade their robot at the competition site. All other FABRICATED ITEMS to be used on the robot during the competition must arrive at the competition venue packed in the shipping crate with the robot.
- <R30> Mechanisms or components on the robot must not pose obvious risk of entanglement. If, in the judgment of the inspectors, a device on the robot poses an entanglement risk then the team will be required to remedy the situation before the robot will be allowed to play. If the structure of a component permits easy penetration by an object less than four square inches in cross section, it will invite detailed inspection. For example, nets, loose rope or wire, voluminous sheets of fabric, etc. may be carefully inspected for these hazards. Willful entanglement actions are addressed in Rule <G23> in *Section 4.3.4 – Robot Operations* of “The Game” section.
- <R31> No devices or decorations are permitted on the robot that are intended to jam or interfere with the operation of the vision system (i.e. changing robot color to confuse opponent’s vision system).
- <R32> Robot wheels, tracks, and other parts intended to provide traction on the playing field may be purchased or fabricated (“traction devices” include all parts of the robot that are designed to transmit any propulsive and/or braking forces between the robot and the playing field). In no case will traction devices that damage the carpet or other playing surfaces be permitted. Traction devices may not have surface features such as metal, sandpaper, hard plastic studs, cleats, or other attachments. Anchors, i.e. devices that are deployed/used to keep one’s robot in one place and prevent it from being moved by another robot, cannot use metal in contact with the carpet or other playing surfaces to “stay put.” Gaining traction by using adhesives or Velcro-like fastener material is not allowed.

<R33> Adhesive backed tapes are NOT allowed except as follows:

- Velcro tape, any hook and loop tape or double-sided sticky foam may be used for attaching components to the robot.
- Reflective tape may be used with optical sensors in small amounts.
- Adhesive backed tape and labels may be used for labeling purposes on wires, cables, pneumatic lines, etc.
- Electrical tape may be used as an electrical insulator.

<R34> Lubricants may be used only to reduce friction within the robot. Lubricants shall not be allowed to contaminate the playing field components, or other robots.

<R35> The use of bumpers is strongly encouraged. Bumpers can reduce damage to robots when they contact another robot or field elements. If you choose to use the specified bumpers, you will have both a more robust robot and the traction advantage of a heavier robot. Bumper height has been specified so that robots will make contact bumper-to-bumper and so that the balls will be pushed rather than pulled under the robots. Note that robot wheel/tracks must be properly positioned relative to the bumpers to avoid trouble climbing the ramp. Obviously harvesting balls from the floor or launching balls along the floor must be done through gaps in bumpers or over bumpers. As the bumper mounts are being designed, please think about carrying the robot. The bumpers do not make good handles. Please do not “lawyer” the bumper rule - it is meant to help. If used, bumpers must satisfy the following constraints:

- Bumpers must be designed as shown in figure 5-1
- Bumpers must be removable so that they can be weighed separately from the robot
- Bumpers must weigh, in total, no more than 15 pounds including any fasteners that attach them to the robot
- Bumpers must not include sections that weigh more than 3 ounces per inch (i.e. no short bumpers with giant heavy fasteners)
- Bumpers must use a stacked pair of 2-1/2 inch “pool noodles” as the bumper material
- Bumpers must use 3/4 inch plywood backing 5 inches tall as the bumper structure to attach the bumper (“pool noodles”) to the robot
- Bumpers must be covered with a tough smooth cloth (1000 denier Cordura Plus® strongly recommended)
- At the start of the match bumpers may extend outside the horizontal starting dimensions for the robot (as specified in Rule <R05>) by up to a maximum of 3-1/2 inches per side, nothing other than pool noodles and cloth may extend more than 1 inch beyond the robot boundaries
- Bumpers must be positioned on the robot so that they remain between 2-1/2 inches and 8-1/2 inches above the floor

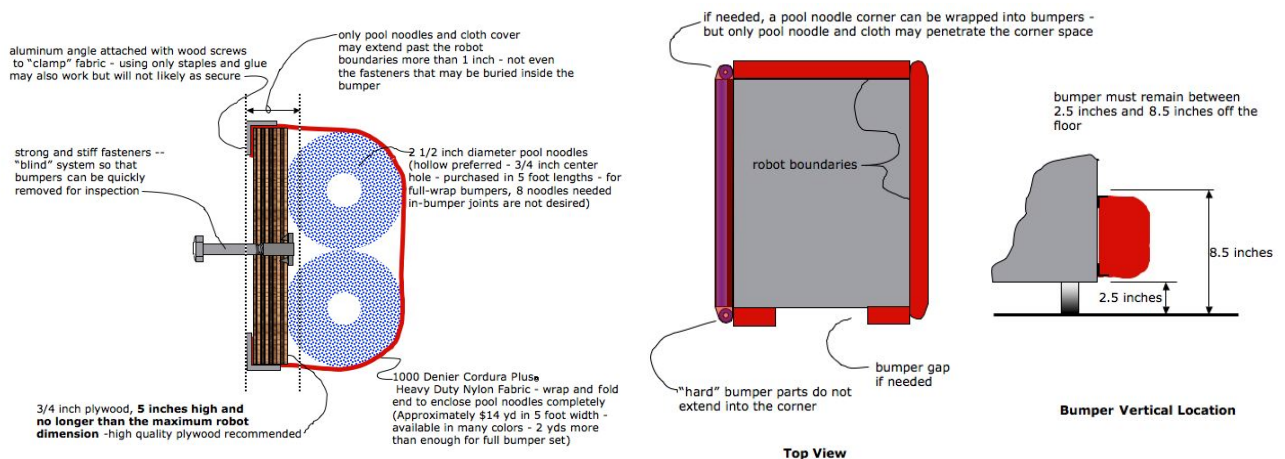

Figure 5-1

5.3.4.1 Kit of Parts Rules

<R36> So that every robot's maximum power level is the same, the motors in the kit may **not be modified in any way**, except as follows:

- The mounting brackets and/or output shaft/interface of the motors may be modified to facilitate the physical connection of the motor to the robot and actuated part.
- The gearboxes for the Fisher-Price, and Globe motors are not considered "integral" and may be separated from the motors. FIRST will not provide replacements for parts that fail due to modification.
- The electrical input leads on the motors may be trimmed to length as necessary.

The intent is to allow teams to modify mounting tabs and the like, not to gain a weight reduction by potentially compromising the structural integrity of any motor. The integral mechanical and electrical system of the motor is not to be modified.

<R37> Teams may replace lost or damaged Kit COMPONENTS only with identical COMPONENTS of the same material, dimensions, and treatment.

<R38> Materials in the Kit may not be changed chemically with the following exceptions:

- Rope ends may be singed to prevent loose ends or to bind them together
- Metal may be heat treated
- Metal may be plated or anodized

5.3.4.2 Additional Parts and Materials Rules

Besides items directly supplied in the 2006 Kit, teams are allowed to use Additional Parts and Materials in the construction of their robots.

<R39> The use of an Additional Part or Material shall not violate any design rule.

<R40> Additional Parts shall not be made from hazardous materials or be unsafe.

<R41> Additional Parts must be generally available from suppliers such that any other FIRST team, if it so desires, may also obtain them at the same price. A specific device **fabricated by a team** from non-2006 Kit materials does not have to be available to others; however, the materials it is made from must be available to other teams.

<R42> The costs of all Additional Parts and Materials must be in compliance with the Cost Accounting Rules of Section 5.3.4.3.

<R43> Specific items allowed include:

- Additional HITEC HS-322HD Servos.
- Additional Victor 884 Speed Controllers and Spike Relays, as needed.
- Additional solenoid valves, air cylinders, and connecting fittings.
- Teams may purchase either one additional 4-slot Maxi-block circuit breaker panel and/or one 2005 FRC circuit breaker panel, and utilize it on their 2006 robot in addition to, or in replacement of, the circuit breaker panels provided in the kit of parts.

- Teams may utilize one or two additional small CIM motors (part #FR801-001) in addition to those provided in the kit of parts. This means that you may use up to four, and no more, small CIM motors on the robot.

<R44> Specific items NOT allowed include:

- Batteries different from or in addition to those provided in the Kit.
- Circuit breakers different from those provided in the Kit. Note: the Snap Action brand circuit breakers provided have unique “trip” characteristics. No substitute brands are permitted.
- Electric motors different from or in addition to those in the Kit, with the exception of those specifically permitted by Rule <R43>.
- Any air compressor, pressure relief valves, or air storage tanks other than those provided in the Kit.
- Hydraulic fluids or hydraulic components.
- Materials classified as hazardous by their MSD Sheets (teams should provide MSD Sheets for any materials they use that might be considered questionable during robot inspection).

<R45> Additional electronic components for use on the robot must be either COTS items, or assembled from COTS items. Additional electronic components include any object that conducts electricity other than IFI relays and speed controllers, wires, connectors and solder.

<R46> Refer to the Part Use Flowchart to help determine the legality of a part.

START HERE
May we use a part or material on our robot?

2006 Parts Use Flowchart

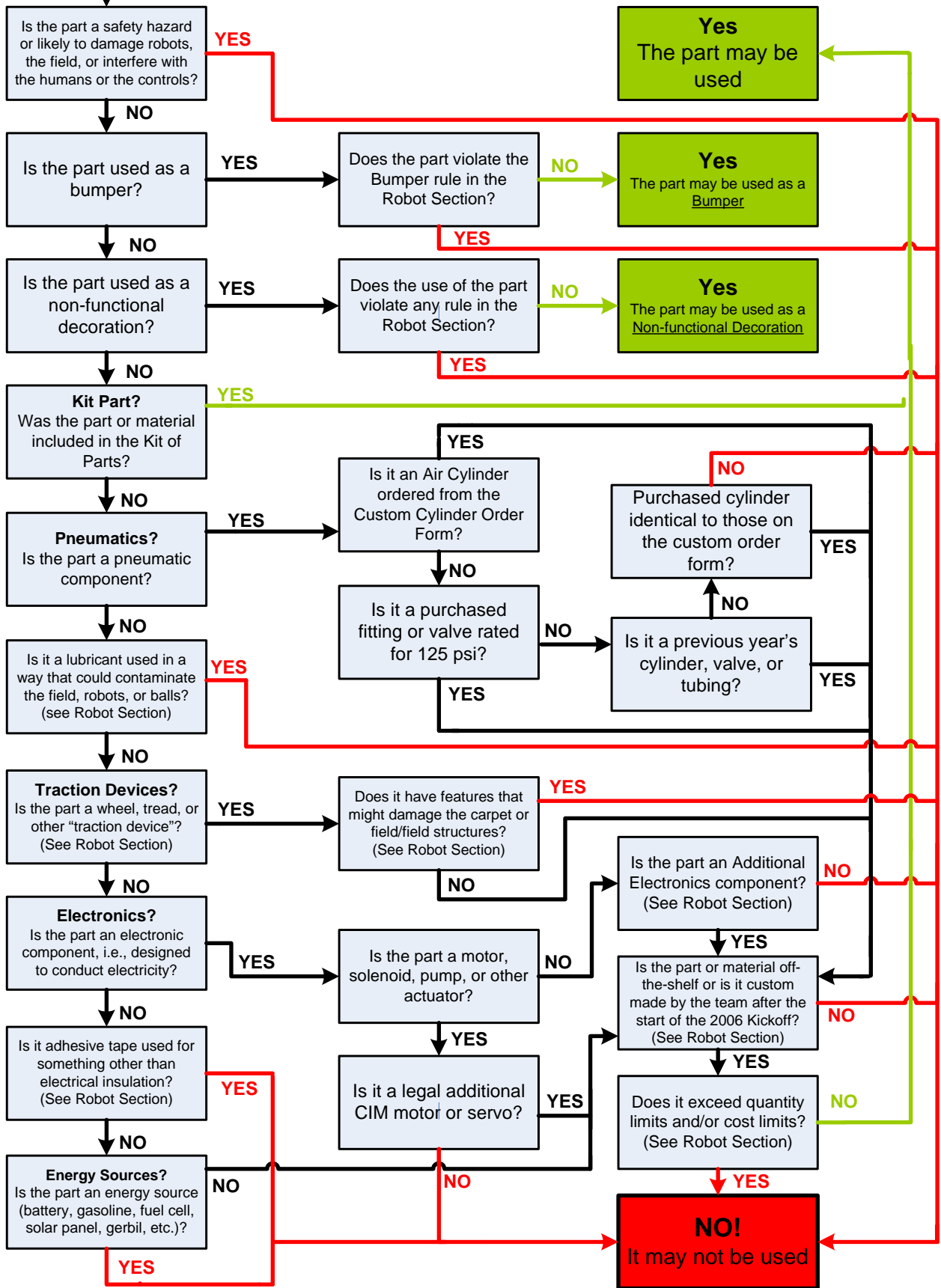

5.3.4.3 Cost Accounting Rules

<R47> The costs of all non-2006 Kit parts and materials used in the construction of a ROBOT (as defined in 5.1.1) must be recorded (in US dollars) by the team, and a list of all such items and their costs presented at robot inspection. **An Additional Part or Material is defined as an allowed additional quantity of any part provided in the 2006 Kit, or any item that was not included in the 2006 Kit's inventory list.**

<R48> All costs are to be determined as explained in *Section 5.3.4.4 - Additional Parts - Cost Determination.*

<R49> The total cost of all non-Kit items may not exceed \$3,500.00 USD. No individual COTS electronic component shall have a value of over \$200.00 USD. No individual non-electronic item shall have a value of over \$400.00. The total cost of components purchased in bulk may exceed \$400.00 USD as long as the cost of an individual component does not exceed \$400.00. The following items are EXCLUDED from the total cost calculation:

- The cost of any non-functional decorations
- The cost of individual fasteners, adhesives, or lubricants, unless any one component exceeds \$1.00
- The costs of SPARE PARTS. A SPARE PART used as a direct replacement for a failed or defective robot part (either Kit part or non-Kit part) that has already been included in the cost accounting is covered by the accounting for the original part.
- The costs of additional Speed Controllers and Spike Relays obtained from Innovation First Inc. for use with Kit motors.
- All costs for the construction of devices used to control the robot from the Alliance Station (i.e. the operator interface and any associated custom equipment).

<R50> The costs of additional non-spare robot control system components obtained from Innovation First Inc. other than Speed Controllers and Spike Relays are to be included in the above \$3500 limit.

5.3.4.4 Additional Parts - Cost Determination

The "cost" of each additional item is calculated based on the following criteria, as applicable:

- The purchase price of a COTS item offered for sale by a vendor to any customer.
- The total cost (materials + labor) of an item you pay someone else to make.
 - Example: A team orders a custom bracket fabricated by a vendor to the team's specification. The vendor's material cost and normally charged labor rate apply.
- The fair market value of an item obtained at a discount or as a donation. Fair market value is that price at which the item would be normally offered by the supplier to other customers. Also considered to be "fair market value" are the discounted prices offered to all teams by suppliers with established relations with FIRST.
 - Example: Special price discounts from MSC Industrial Supply Co. and Terminal Supply Co. are being offered to all FIRST teams. The discounted purchase price of items from these sources would be used in the additional parts accounting calculations.
- The cost of raw material obtained by a team + the cost of non-team labor expended to have the material processed further. Labor provided by team members and/or by a recognized team sponsor whose employees are members of the team does not have to be included. Note: it is in the best interests of the teams and FIRST to form relationships with as many organizations as possible. Teams are encouraged to be expansive in recruiting and including organizations in their team, as that exposes more people and organizations to FIRST. Recognizing supporting companies as sponsors of, and members in, the team is encouraged - even if the involvement of the sponsor is solely through the donation of fabrication labor.
 - Example: A team purchases steel bar stock for \$10.00 and has it machined by a local machine shop. The machine shop is not considered a team sponsor, but donates two hours of expended

labor anyway. The team must include the estimated normal cost of the labor as if it were paid to the machine shop, and add it to the \$10.00.

- Example: A team purchases steel bar stock for \$10.00 and has it machined by a local machine shop that is a recognized sponsor of the team. The machinists are considered members of the team, so their labor costs do not apply. The total applicable cost for the part would be \$10.00.
- The cost of items purchased in bulk or large quantities may be prorated on the basis of the smallest commonly available unit that satisfies the need for the item.
 - Example: A team purchases a 4' x 4' sheet of aluminum, but only uses a piece 10" x 10" on their robot. The team identifies a source that sells aluminum sheet in 1' x 1' pieces. The team may cost their part on the basis of a 1' x 1' piece, even though they cut the piece from a larger bulk purchase. They do not have to account for the entire 4' x 4' bulk purchase item.
- Shipping costs of Non-Kit items are not counted.
- COMPONENTS or MECHANISMS that teams purchase to replace kit parts that were not received from FIRST are not subject to the cost limitation (i.e., should not be charged against the \$3,500 robot limit).

5.3.5 Electrical System Rules

<R51> The only legal main source of electrical energy on the robot is the 12VDC non-spillable lead acid battery provided in the Kit of Parts. That 12V battery is the Exide type EX18-12. The ES18-12 battery, purchased through your local Exide supplier as a spare, is identical and may also be used. You may use other equivalent type 12V batteries, but only during the Thursday practice rounds.

The 7.2v “backup” battery is considered an integral part of the Robot Controller, and may not be used for any other purpose.

<R52> The EX18-12 or ES18-12 Battery may only be charged by a 6 Ampere rated Automatic Battery Charger between matches. When recharging the Kit batteries, you may use the charger provided by FIRST or an automatic charger with an equivalent charging current rating.

<R53> The 7.2v backup battery may be charged on or off the robot. When off the robot, the battery is to be charged with the provided 7.2V backup battery charger. When mounted on the robot, the backup battery may be charged from the 12VDC primary battery by using the custom charging circuit available from Innovation First Inc. (note: IFI will provide the design for this circuit on the IFI website, however teams must obtain the parts for this circuit and assemble it themselves)

<R54> The 12V Battery, the Main 120 Amp Circuit Breaker, and the Circuit Breaker distribution panels must be connected as shown in the 2006 (or optionally) as in the 2005 diagrams shown below. The Battery must use the Anderson Connector. The connector must be attached with either the copper SLU-35 lugs provided in the Terminal Supply Bag or appropriate crimp-on lug connectors. The Battery terminals and the connecting lugs must be insulated with shrink tubing and/or electrical tape. You may use additional lengths of #6 red and #6 black wire to reach the panels as needed to make the above connections. The circuit breakers must be readily accessible for inspection and testing at each competition event.

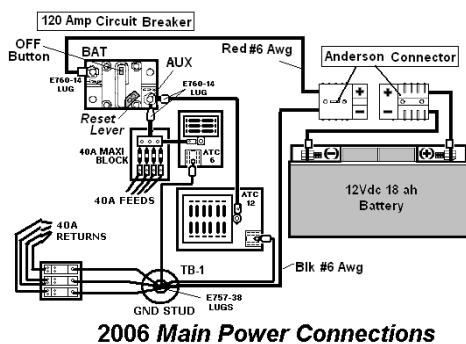

2006 Main Power Connections

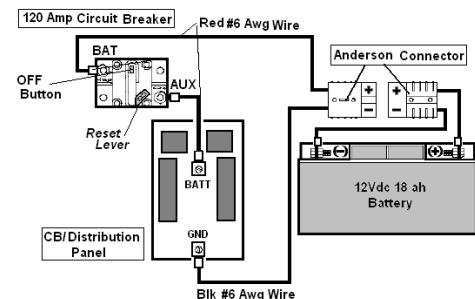

2005 Main Power Connections

<R55> All wiring and electrical devices must be electrically isolated from the robot frame; the robot frame may not be used to carry electrical current (this isolated ground arrangement is necessary due to polarity reversals that occur under certain operating conditions such as during motor direction reversals).

<R56> All 12v electric power used on the robot must be obtained from the load terminals of the Circuit Breaker distribution panels. Each branch circuit must be protected using the appropriate value circuit breaker as specified in Section 5.3.9.1 “Circuit Breaker/Fusing Rules.”

5.3.6 Custom Circuit Rules

<R57> The use of additional electronics is intended to allow teams to construct custom circuits for their robots. The custom circuits may be used to indirectly affect the robot outputs by providing enhanced sensor feedback to the Robot Controller to allow it to more effectively decide how to control the robot. In addition to the required branch power circuit breaker, smaller value fuses may be incorporated in the custom circuits for additional protection. All outputs from the custom circuits must be connected to the analog inputs, digital I/O, TTL Serial Port, or Program Port on the Robot Controller.

<R58> Inputs to custom circuits may be connected to the following sources:

- Branch Circuit breaker outputs
- Speed Controller or Relay module outputs
- PWM, Relay or Digital Outputs on Robot Controller
- Switches, Potentiometers, Accelerometers, Sensors, and other additional permitted electronics.

<R59> Custom Circuits may **not**:

- Interfere with the operation of other robots
- Directly alter the power pathways between the battery, fuse blocks, speed controller/relay, and motor. Custom high impedance voltage monitoring or low impedance current monitoring circuitry connected to the robot’s electrical system is acceptable, because the effect on the robot outputs should be inconsequential.
- Directly affect any output devices on the robot, such as by providing power directly to a motor, supplying a PWM signal to a speed controller or supplying a control signal to a relay module
- Be used for wireless communication, such as sending or receiving a signal to and/or from the alliance station
- Connect to the radio or tether ports on the Robot Controller

5.3.7 Control System Rules

<R60> You must operate your robot with the wireless, programmable Innovation First 2006-Robot Control System.

<R61> The control system is provided to allow wireless control of the robots. The Operator Interface, Robot Controller, Speed Controllers, Relay Modules, Radio Modems, Batteries, Battery Charger, AC Adapter, and 9-pin cables may not be tampered with, modified, or adjusted in any way, (tampering includes drilling, cutting, machining, gluing, rewiring, etc.) with the following exceptions:

- The dip switches on the Operator Interface may be set as appropriate.
- The user programmable code in the Robot Controller may be customized.

- The Speed Controllers may be calibrated as described in owner's manuals.
- The fuse on the Spike relay for the Air Compressor may be replaced with a 20 Amp Snap-Action circuit breaker.

<R62> Teams are responsible for any software bugs introduced into the Robot Controller's control program when using a custom program or for any unwanted or unanticipated robot behavior when using additional electronics.

<R63> The Robot Controller must be positioned within the robot so that its indicator lights may be seen during inspection and during operation in a match. This will greatly facilitate analysis in case of problems.

<R64> All circuit breakers must be accessible for inspection at each FIRST Robotics Competition event.

<R65> The team number settings on the Operator Interface must be set to the team number assigned to the team by FIRST, then the Robot Controller must be tethered to the Operator Interface to transfer the Team Number setting to the Robot Controller. This must be done only once after setting the Operator Interface.

<R66> Do not connect 12Vdc power, Relay Module outputs, Speed Controller outputs, or PWM outputs to the analog or digital I/O on the Robot Controller.

<R67> You must connect all outputs from the sensors and additional electronics circuits used on the robot directly to the analog or digital I/O on the Robot Controller. ***Sensors may not be wired so that they directly control other devices.*** All loads must be controlled by PWM signals sent by the Robot Controller to relays or speed controllers. It is acceptable to wire switches used as sensors in series or parallel with each other.

<R68> The 7.2V Robot Control backup battery must be connected to the Controller as described in the Controller's manual. The 7.2v battery should be charged to at least 7.0v before entering a match. As a replacement for the FIRST supplied battery, any other 7.2V NiCad battery pack may be used.

<R69> A remote reset and remote programming switch may be wired to the Robot Controller's RESET/PROG header. Any switch may be used. See the ***Robot Controller Reference Guide*** for wiring information.

<R70> Digital outputs of the Robot Controller may be connected directly to brake/coast headers on the speed controllers to permits programmable control of this speed controller function. The brake/coast header on the speed controller may NOT be connected to any other circuit or input.

<R71> Unaltered software modules developed during prior competitions may not be directly re-used. Just as designs for hardware COMPONENTS may be reused from one year to the next, software algorithms and designs may be reused. However, the specific lines of code must be customized for each robot each year.

5.3.8 Operator Interface Rules

<R72> The team number settings on the Operator Interface must be set to the team number assigned to the team by FIRST.

<R73> The Operator Interface Console designed by your team must fit on the 69" wide by 12" deep shelf in the Alliance Station.

- <R74> Teams are permitted to connect a portable computing device (Laptop computer, PDAs, etc.) to the RS232 Output of the Dashboard Port of the Operator Interface for the purpose of displaying feedback from the robot while competing in Competition matches. Please note that ***AC power will not be available at the playing field so these devices will have to run on internal batteries.***
- <R75> The IFI Operator Interface (OI) must be positioned within the operator console so that its indicator lights may be seen during inspection and during operation in a match. This will greatly facilitate analysis in case of problems.
- <R76> Teams may not use Innovation First Operator Interfaces from previous years' competitions.
- <R77> No external equipment may be connected to the Tether Port of the Operator Interface during a match.
- <R78> All equipment connected to the Joystick Ports of the IFI Operator Interface must be powered solely through the power available through the port. External power sources of any type are not permitted on any equipment connected to the Joystick Ports. Portable computing devices *may not* be connected to Joystick input ports on the Operator Interface. Power-passive devices (e.g. joysticks that draw their power solely through the IFI Operator Interface joystick port) are permitted.
- <R79> The Competition Cable at the Alliance Station must connect directly to the Competition Port on the Operator Interface. No intermediate connectors, cables, or "pigtailed" are permitted.

5.3.9 Wiring Rules

- <R80> Electrical devices may only be wired in accordance with ***Section 5.3 Robot Rules***. For your convenience, please refer to the ***2006 Robot Power Distribution Diagram***.
- <R81> All wires distributing power with a constant polarity (i.e., except for Relay Module, Speed Controller, or sensor outputs) must be color-coded as follows:
- Use Red, White, or Brown wire for +12 Vdc and +5 Vdc connections.
 - Use Black or Blue wire for Common (-) connections.
- <R82> *You must use 12 AWG or larger* diameter wire for all circuits protected by a 40A Circuit Breaker.
- <R83> *You must use 14 AWG or larger* diameter wire for all circuits protected by a 30A Circuit Breaker.
- <R84> *You must use 18 AWG or larger* diameter wire for all circuits protected by a 20A Circuit Breaker.
- <R85> *You must use 24 AWG or larger* diameter wire for connecting sensors such as: switches, potentiometers, accelerometers, and other sensors. *You must use 24 AWG or larger* diameter wire for connecting a Vision System to Robot Controller inputs, and for extending the PWM cables, for the small muffin fans, or for wiring LEDs. It is acceptable to use ribbon cable smaller than 24 AWG to connect to the 9 pin ports on the Robot Controller.
- <R86> No more than one motor may be connected to each Speed Controller.

<R87> CIM motors and Fisher-Price motors must be connected to Speed Controllers. They may not be connected to Relay Modules.

5.3.9.1 Circuit Breaker / Fusing Rules

<R88> You must use the auto resetting Snap Action circuit breakers provided in the Kit Of Parts to protect all the active Circuit Breaker/ Power Distribution Panel branch circuits from overload.

<R89> You must protect the Robot Controller power feed with a 20A Circuit Breaker. You may **not** connect any other electrical load to this breaker.

<R90> You must protect the Air Compressor spike relay power feed with a 20A Circuit Breaker. You may **not** connect any other electrical load to this breaker.

<R91> You must protect the power feed to Custom Circuits and Additional Electronics with a 20A Circuit Breaker.

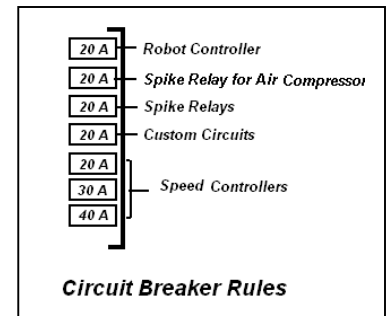

<R92> Speed Controllers may be protected by 20A, 30A, or 40A Circuit Breakers. Speed Controllers may power motors or devices of any size.

<R93> SPIKE Relay Modules must be protected with a 20A Circuit Breaker. Multiple devices may be connected to Relay Modules if desired (but only one motor may be connected to each Relay Module).

5.3.10 Pneumatic System Rules

Please refer to the *Pneumatics Manual* for additional information about using pneumatics on your robot.

<R94> Pneumatic components supplied in the Kit compressor, regulators, pressure switches, cylinders, valves, fittings, tubing, etc.) may not be modified except as follows:

- The tubing may be cut.
- The wiring for the valves and pressure switch may be modified as necessary to interface with the rest of the control system.
- Mounting and connecting pneumatics components using the pre-existing threads, mounting brackets, etc., is not considered a modification of the components. Removing the pin from the rear of an air cylinder is allowed as long as the cylinder itself is not modified.
- Do not, for example, file, machine, or abrasively remove any part of an air cylinder. Consider pneumatic components sacred. They must remain in “out of the shipping box” condition.

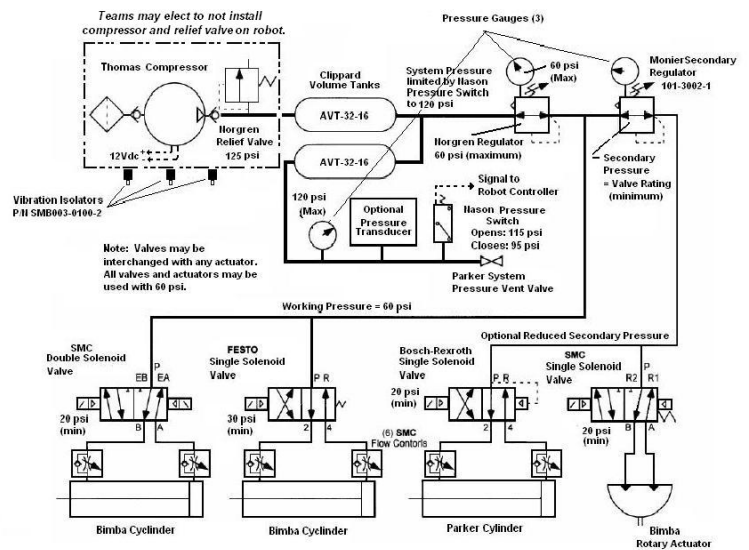

AN EXAMPLE OF A TYPICAL PNEUMATICS SYSTEM

<R95> The compressor may be mounted on the robot, or if teams prefer, they may leave it off their robot, and pre-charge and store compressed air in the storage tanks prior to bringing their robot onto the playing field. If you elect to use pneumatics on your robot, your pneumatic system must contain as a minimum the following components, connected in accordance with this section.

- Pressure gauges to display the “working” and “stored” air pressure.
- An accessible pressure vent valve to manually relieve the stored pressure

<R96> **Teams are not allowed to remove or adjust the 125-psi set relief valve attached to the compressor.**

You may only use the Thomas Industries compressor and Clippard Instruments air storage tanks provided in the Kit to compress and store air on the robot. You may not use extraneous lengths of pneumatic tubing to increase the storage capacity of the air storage system.

<R97> The Nason pressure switch must be connected to the output end of one of the Clippard tanks to sense the tank’s pressure. The two wires from the pressure switch must be connected directly to a digital input and ground terminal on the Robot Controller, and the controller must be programmed to sense the state of the switch and operate the spike relay that powers the compressor. The Parker Pressure Vent valve must be connected to a Clippard tank such that, when manually operated, it will vent to the atmosphere to relieve any stored pressure. The valve must be placed on the robot so that it is visible and accessible.

<R98> “Working” air pressure on the robot must be no greater than 60psi. All working air must come from the Norgen adjustable pressure regulator, and all other pneumatic components must be downstream from this regulator. A pressure gauge must be placed adjacent to the pressure regulator and display the downstream pressure.

<R99> There is no limit to the number of solenoid valves, air cylinders, pressure regulators, and connecting fittings you may use on your robot. They must, however, be “off the shelf” pneumatic devices rated by their manufacturers for pressure of at least 125psi. Besides the “free” pneumatic components listed on the Pneumatic Components Order form, you may purchase additional air cylinders or rotary actuators, however, they must be identical to those listed on the Pneumatic Components Order form (i.e. same part numbers), and obtained from a Bimba or Parker Hannifan distributor.

<R100> The following pneumatics items may be added to your robot:

- You may use the 2005 Kit pneumatic cylinders, solenoid valves, and pneumatic tubing in addition to those items in the 2006 Kit, but you must account for their costs as explained in the Cost Limits and Accounting section.
- You may use a pressure transducer as long as it is rated to the operating air pressure at its mounting point in the pneumatic system.
- For the purposes of the FIRST competition, a device that creates a vacuum is not considered to be a pneumatic device and is allowed. This includes, but is not limited to, Venturi-type vacuum generators and off-the-shelf vacuum devices (as long as they are powered by one of the Kit-of-Parts motors).
- For the purposes of the FIRST competition, closed-loop pneumatic (gas) shocks are not considered pneumatic devices, and are permitted additions to the robot.

5.3.11 Non-Functional Decoration Rules

Teams may add “Non-functional” decorations to robots under the following conditions:

<R101> Decorations must be on the robot at the time of final inspection, and must not cause the robot weight or size to exceed the Rule requirements.

<R102> Decorations must not affect the outcome of the match, and must be in the spirit of “Gracious Professionalism.”

<R103> Any decorations that involve broadcasting a signal to/from the robot, such as remote cameras, must be cleared with FIRST Engineering prior to use. Teams may **not** use *900 MHz camera systems*.

<R104> Decorations may draw power from the 12v electrical system as long as they are powered via a dedicated 20A or 30A circuit breaker and do not affect the operation of other control system components.

5.3.12 Robot Inspection Rules

FIRST will post a copy of the Official Robot Inspection Sheet in approximately the first week of February. Use this sheet as a guide to pre-inspect your robot before it ships. Note that robot inspectors will be looking for sharp corners and edges that could cause injury. Please try to mitigate all sharp corners.

<R105> All robots must pass inspection for compliance with the Rules herein before being allowed to compete in the Qualification Rounds. At the time of inspection, teams must present a list of all Non-Kit part items and costs used in the construction of their robot to the inspector.

<R106> At Inspection, noncompliance with any robot construction Rule may result in disqualification of the machine at a FIRST competition event. The team must bring the robot into compliance before they will be allowed to compete in the Qualification Rounds. At the discretion of the lead Inspector, the robot may be allowed to participate in practice rounds before passing inspection.

<R107> If a team makes a modification to improve performance or reliability after its robot has passed inspection, that team must have the robot re-inspected. If you observe that another team’s robot may be in violation of the robot rules, please approach FIRST officials to review the matter in question. This is an area where “Gracious Professionalism” is very important.

<R108> At the time of robot inspection, you must present ***all*** mechanisms (including ***all*** components of each mechanism) ***and configurations*** that you will use on the robot during the entire competition event. It is acceptable, however, for a robot to play matches with a **subset** of the mechanisms that were present during inspection. Only mechanisms that were present during the inspection may be added, removed or reconfigured between matches. If subsets of mechanisms are changed between matches, the reconfigured robot must still meet all inspection criteria.

<R109> If a robot is rejected because of a safety issue or concern related to the team’s method of storing energy, the concerned mechanisms must be disabled or removed from the robot before it may compete in a match. The team bears the burden of proof that such a rejection is not valid. Teams should be prepared to provide justifiable test data or calculations during inspection to support their design.

<R110> FIRST Officials may randomly re-inspect robots participating in competition rounds to assure compliance with the Rules

5.4 KIT OF PARTS

FIRST provides a Kit of Parts to each team. Only the exact parts provided in the Kit (or their exact replacement) are considered as Kit Parts. Some Kit Parts may legally be used in additional quantities. Additional quantities of these parts are considered to be “Additional Parts” and not “Kit Parts”.

5.4.1 2006 Kit Changes

Some of the exciting and important changes found in the 2006 Kit Items include:

- Labview8 and Easy C software supplied for vision system software development and programming.
- Removed two of the CIM motors and replaced them with two larger CIM “mini-bike” motors.
- 3 New Sensors for 2006 - Gear Tooth Sensor, Dual Axis Accelerometer, and Angular (Yaw) Rate Gyro. Each provides critical positioning and attitude sensing data for precision robot control.
- Enhanced CMUcam2 Vision System with new servo driven Pan/Tilt Brackets adds the capability for vision-based tracking of illuminated targets - essential to achieving competitive performance skills in this year’s game.
- New igus Linear Bearing and Guide System kit provides robust lightweight components useful for designing efficient mechanical control systems.
- New Allen-Bradley Infrared Transmitted Beam Sensor for any applications where broken beam detection is a useful and important requirement.
- Returned the MAXI and the ATC fuse panels to the kit in place of the single Circuit Breaker/Power Distribution panel.
- Spiraled Pneumatic tubing from Freelin-Wade.

5.4.2 Kit Of Parts Contents

The *FIRST* 2006 Kit of Parts is provided in multiple containers. They consist of; 2 Large plastic Totes (blue and red) of robot parts and construction materials shipped from *FIRST*, cartons containing 1-KitBot box, 1 Electronics Kit, 1 Drive Kit, and 1 Motor Kit shipped from Innovation First, Inc and 2 items.

Use the tables below to inventory your Kit of Parts. The inventory may take about 45 minutes, but should be completed within 48 hours of receiving the kit in order to determine that all items are present. Any irregularities must be reported by 11:59 pm (EST) on Wednesday, January 11, 2006.

The CHECK column should be marked when the item and quantities are correct. All bags are labeled. If you are not sure what a particular part should look like, match the Pix Number to the numbered photograph for clarification. (N/A = picture not available). Kit photos are attached to the checklist supplied with the kits and may be downloaded from the FIRST web site at http://www.usfirst.org/robotics/doc_updt.htm

5.4.2.1 The following part items will be found inside the Blue container

BLUE CONTAINER ITEM 1

		<i>BATTERY BOX</i>	EXIDE	Contains 2 ea.	
✓	Pix	Part Name	Description	Part Number	Qty
	K11	Battery, Exide	12V, 18AH, Deep Cycle	EX18-12	2

BLUE CONTAINER ITEM 2

		<i>COUPLER BAG</i>		MMH	
✓	Pix	Part Name	Description	Part Number	Qty
	K21	Wheel Hub, Plastic	Hub for Skyway wheels	DEKA	4
	K22	Coupler, Nippon-Denso Motor	Injection molded	DEKA Denso_6	2

BLUE CONTAINER ITEM 3

		<i>ELECTRICAL BAG</i>		MMH	
✓	Pix	Part Name	Description	Part Number	Qty
	K31	Connector, Quick Disconnect	#6 Wire Pair, 12"	6331G1	4
	K32	Battery Connector Safety Plug	White (45) small plastic	AndyMark, Inc.	8
	K33	Fan, Muffin (Tiny)	12 Vdc	412	6
	K34	Fan, Muffin, (Large)	12 Vdc	4212/19H-490 or 4112N/12GL	2
	K35	Latex Tubing	¼" ID, 3/8" OD, 5 feet	5234k44	2

BLUE CONTAINER ITEM 4

		<i>FREELIN WADE</i>			
✓	Pix	Part Name	Description	Part Number	Qty
	K41	Spiral Tubing	Coil	2MC-151-5P-FW	1
	K42	Tubing, ¼"	100 Ft length	1J-151-07P-FW	1
	K43	Catalog, Freelin-Wade		FWRGSI	1

BLUE CONTAINER ITEM 5

		<i>LOOSE MATERIALS</i>			
✓	Pix	Part Name	Description	Part Number	Qty
	K51	Coil, Wire, Black	10' , # 6 AWG, Black	Delphi Conn. Systems	1
	K51	Coil, Wire, Red	10' , # 6 AWG, Red	Delphi Conn. Systems	1
	K52	Battery Charger, Automatic	6 Amp, Midtronics	CXC-2005	1
	K54	Ball, 7" Foam Basketball	Sport balls	Poof-slinky.com	1
	K55	Motor, Fisher-Price, w/19T #7 Gearbox	12 Vdc	00968-9003 or 00968-9012 supplied	2
	K56	Wheel, wheelchair, 8"	Precision Hub w/o brg.	WHL70C	4

BLUE CONTAINER ITEM 6

		<i>MAGAZINE BAG</i>		May be loose in Tote	
✓	Pix	Part Name	Description	Part Number	Qty
	N/A	Magazine, Nuts and Volts			1
	N/A	Magazine, Servo			1

BLUE CONTAINER ITEM 7

<i>TARGET BAG</i>					
↳ Pix	Part Name	Description	Part Number	Qty	
K71	Cold Cathode Dual Kit	12" green (2 bulbs/box)	Oznum	4	
K72	Transformer		Oznum	4	
K73	Target Lens, HDPE Panel	16" x 8"(nom) x 1/8"	Plastic Supply	1	

BLUE CONTAINER ITEM 8

<i>TERMINAL SUPPLY BAG</i>					
↳ Pix	Part Name	Description	Part Number	Qty	
K81	Circuit Breaker, 120A, Buss	120A, Automotive style	CB3-SM-120 185-120-F01-1(old)	1	
K82	Nylon Ring Terminal	AWG 22-18	A-532-06	10	
K83	Nylon Ring Terminal	AWG 16-14	B-523-06	6	
K84	Maxi Style Fuse Block, 4 Position	Gold plated	JEF-531D	1	
K85	Terminal Lug, SLU-35	6-14ga solderless lug	SLU-35	8	
K86	ATC Fuse Panel,	12 Position	15600-12-21	1	
K87	ATC Fuse Panel,	6 Position	15600-06-21	1	
K88	Nylon Ring Terminal	#6ga- 1/4" stud	E760-14	4	
K89	Nylon Ring Terminal	#6ga- #10 stud	E760-10	6	
K810	Nylon Ring Terminal	#6ga- 3/8" stud	E757-38	6	
K811	Female Quick Disconnect, Nylon	12-10ga, .250d	C-572	56	
K812	Nylon Ring Terminal	12-10ga Ring Lugs	C-536-06	20	
K813	Fem Quick Disconnect, Nylon	22-18ga, .250d	AA-8140	8	
K814	Fem Quick Disconnect, Nylon	10-12ga, .250d	C-850	14	
K815	Male Quick Disconnect, Nylon	16-14ga, .250d	MCT-850	14	
K816	Fem Quick Disconnect, insulated	16-14ga, .250d	B-850	4	
K817	Stud w/ Nut	3/8" stud terminal block	TB-1	1	
K818	Male Quick Disconnect, Nylon	12-10ga, .250d	MCT-C-850	14	

5.4.2.2 The following part items will be found inside the Red container

RED CONTAINER ITEM 1

<i>IGUS BAG</i>					
↳ Pix	Part Name	Description	Part Number	Qty	
KR11	Igubal Pillow Block- 5/8"	2 in separate bag in Tote	KSTI-10	4	
KR12	Iglide Flange Bearing-5/8"		JFI-1012-12	4	
	IGUS Product Guide			1	
KR14	Plastic Linear Bearing	5/8"	RJI-01-10	2	
KR15	5/8" Aluminum Shafting	18" Hard Anodized	AWI-10	1	
KR15	3/8" Aluminum Shafting	18" Hard Anodized	AWI-06	1	
KR17	Iglide Sleeve Bearing-5/8"		JSI-1012-12	4	
KR18	2-Hole Flange Bearing- 3/8"		EFOI-06	2	
KR19	Clevis Joint w/pin & Clip	3/8"	GERIK-06	2	

	KR110	5/8" Rod end Bearing		EBRI-10R	2
	KR111	3/8" Rod end Bearing		EBRI-06R	2
	KR112	EZ Chain	18" Long	Z06-16-018-0	1
	KR113	Mounting Bracket – EZ Chain	1 Set/ 2 Pieces	060-16-12PZ	1
	KR114	Low Profile Linear Guide 27mm wide	2 pieces, 18" Long, 4 carriages	NK01-27-2-457	2

RED CONTAINER ITEM 2

LOOSE MATERIALS					
	Pix	Part Name	Description	Part Number	Qty
	KR21	Motor, Globe, w/drive assy	12 Vdc	409A587	2
	KR22	Volume Tank, Clippard	2" bore by 6" long	AVT-32-16	2
	KR23	Motor, CIM	Keyed output shaft	FR801-001	2
	KR24	Motor, Nippon-Denso Window, RH		262100-3030/ RH	1
	KR25	Motor, Nippon-Denso Window, LH		262100-3040/ LH	1
	KR26	Motor, Sliding Door, Van	Bosch	16636815	1
	KR27	Joystick, Analog	AVB Top Shot Analog	GC-1000FR	2
	KR28	Rod Clevis Kit		LO7130 0400	1
	KR29	Pivot Bracket Set (R/L)		LO7131 0300	1
	KR210	Lead Screw w/ Nut		BZ6050 x 12"	1
	KR211	Motor, Mabuchi		RS-545SH-2485	1
	KR212	Cylinder	1.5" bore x 8" stroke; rear pivot	1.5DPSR8.00	1
	KR213	Compressor, Thomas		405ADC38/12	1
	KR214	US Patent + Trademark Office	DVD		1
	KR215	80/20 CD			1
	KR71	MSC Catalogue – CDROM	& Starrett table		1
	KR216	FedEx Envelope			1

RED CONTAINER ITEM 3

	Pix	Part Name	Description	Part Number	Qty
	KR30	PNEUMATICS – SMC	<i>Note: 24V solenoid</i>	<i>is an extra item</i>	
	KR31	Flow Control		NAS2201F-N01-07S	6
	KR32	Fitting, Straight	¼" tube, straight	KQH07-34S	10
	KR33	Fitting, 90 Elbow	¼" tube, 90° elbow	KQ2L07-34S	5
	KR34	Solenoid Valve, Double w/ Lead Wire Assy, Pilot Valve & gaskets	12VDC pilot valves hardwired to assy.	SY3240-6HZ-X70	2
	KR314	Solenoid Valve, Double w/ Pilot valves 24VDC	24VDC, no lead wires	SY3240-5LOZ (Spare for solenoid)	1
	KR37	Sub Base,	1/8" ports	SY3000-27-1T	2
	KR38	Fitting, 90 Elbow	90° Elbow ¼" tube	KQLO7-35S	10
	KR39	Fitting, Tee-Union	Tee union –1/4" tube	KQTO7-00	5

	KR312	Fitting, 90 Elbow	Male, 90° Elbow, 5/32" tube- 1/8 NPT	KQ2L03-34S	1
	KR313	Fitting, Straight	Male Conn. 5/32" tube -1/8 NPT	KQ2H03-34S	1

RED CONTAINER ITEM 4

<i>PNEUMATICS BAG #1</i>					
	Pix	Part Name	Description	Part Number	Qty
	KR41	Teflon Tape	1/4" x 520'		1
	KR42	Pressure Gauges, Wika	1/8" NPT, 0-160 psi	9690242	2
	KR43	Solenoid, Festo, Single valve kit	Single solenoid valve	VPLE18-M5H-4/2-1/4	2
	KR44	Vibration isolators, Lord		SMB003-0100-2	3
	KR45	Secondary Regulator & Bracket, Monnier	Regulator & Mtg Kit	101-3002-1	1
	KR46	Pressure Switch, Nason	Open; 115, Close; 95psi	SM-2B-115R	1
**	KR47	Main Regulator, Norgren, 60psi	60 psi Max output	R07-153-RNEAJ060	1
	KR48	Regulator Mounting Kit	Bracket & Nut	18-025-003	1
	KR49	Relief Valve, Norgren, 120 psi	120 psi Relief Valve	16-004-074	1
	KR410	Gauge, Norgren	Gauge, 0-160 psi	18-013-212	1
	KR411	Parker Brass Bag			1

** Verify part number is R07-153-RNEAJ060

RED CONTAINER ITEM 5

<i>PNEUMATICS #2 BAG</i>					
	Pix	Part Name	Description	Part Number	Qty
	KR51	Valve, BoschRexroth	Valve, 12V	5728400410	1
	KR52	Connector kit, BoschRexroth	Connector, & hwre	H894101-02202	1
	KR53	Nut, BoschRexroth	Gray Nut - 1/4" tubing	H893071-4904	3

RED CONTAINER ITEM 6

<i>SENSOR BAG</i>					
	Pix	Part Name	Description	Part Number	Qty
	KR61	Receiver	Combine Rx & Source	42SMR-7100	1
	KR62	Source	Rockwell Automation	42SML-7100	1
	KR63	Power Distribution Block	Rockwell Automation	1492-PDM 3141	1
	KR64	Micro switch	Sager Electronics	V7-2B17D8-048	2

5.4.2.3 The following part items are shipped from Innovation First

INNOVATION FIRST, INC. ITEM 1

<i>FIRST-2006 ELECTRONICS KIT</i>				E-KIT-2006	
	Pix	Part Name	Description	Part Number	Qty
	IF16	Robot Controller Unit	ROBOT-RC	FR-2006-RC	1
	IF17	Operator Interface Unit	ROBOT-OI	FR-2006-OI	1
	IF13	Radio Modem – Robot Controller	RS-422, 9 pin, M, w/ Rubber Antenna	ROBOT-RADIO-RC	1
	IF14	Radio Modem – Op. Interface	RS-422, 9 pin, M, Metal Antenna	ROBOT-RADIO-OI	1
	IF110	Speed Controller, Victor 884	VICTOR-884-12-12	FR-VIC884	4
	IF18	Cable, PWM/Relay	Hitec/JR –36”	CABLE-PWM-36	8
	IF19	Cable, PWM/Relay – Y	Hitec/JR –24”	CABLE-PWM-Y	2
	IF119	Adapter, 7.2V Battery Charger	Old Connector to Spade-Lock	ADAPT-BATTERY- 7.2	1
	IF11	Cable, 9 pin, M/F, Blk, 6”	DB9 M/F 6’, Shielded	CABLE-DB9-6FT-MF	3
	IF111	Cable, 9-Pin, 6’, Tether	DB9 Female/Female	CABLE-DB9-6FT-FF	1
	IF117	Battery, 7.2V, NiCad, Backup	7.2V NiCad	BATTERY-BACK-7.2	1
	IF124	Wall Adapter – OI	AC/DC Adapter 9VDC	AC-ADAPTOR-OI	1
	IF12	Servo	42 oz/in peak torque 0.19	SERVO-HS-322HD	2
	IF120	Circuit Breaker Bag	20Ax4, 30Ax2, 40Ax4	CB-20A, CB-30A, CB- 40A	1
	IF123	MPLAB CBOT Compiler	MicroChip Software	C-BOT-COMPILER	1
	IF128	LabView Software	Student Edition	National Instruments	1
	IF15	Spike Relay	12v, 20A	SPIKE-RELAY-H	4
	IF115	Camera Pan/Tilt Bracket Kit	3 Brackets plus h/w	FRC-PANTILT-01	1
	IF122	LED Cluster	Robot LED, Red/Blue	ROBOT-LED-RB	1
	IF112	Camera Lens	Camera Lens	CAMERA-CMU-2	1
	IF113	CMU CAM Printed Circuit Board	CMU-CAM-2 PCB	CAMERA-CMU-2	1
	IF114	TTL-232	TTL–RS232 Converter	CAMERA-CMU-2	1
**	IF125	Sensor Strip	DAA, YRG, GTSx2	SENSOR-STRIP-01	1
	N/A	Gear-Tooth Sensor Hardware	Not Used	See Motor kit item 3	1
	IF127	Picasa Software Ver 2.0 on CD	for Google Camera		1

** Note: See <http://www.ifrobotics.com/> BEFORE wiring the YRG sensor.

INNOVATION FIRST, INC. ITEM 2

<i>FIRST 2005 KITBOT</i>				FRC-KITBOT-001	
	Pix	Part Name	Description	Part Number	Qty
	IF31	Transmission Support Frame	Metal plate, 30” x 5”	KITBOT-TRAN-TOP	1
	IF32	Bumper, C-Channel	Metal C- channel, 37”	KITBOT-BUMPER	2
	IF33	Main Chassis Rail	Rail	KIT-BOT- RAIL	4
	IF34	End Cap	U-shaped C-channel	KITBOT-ENDCAP	4
	IF35	Mount Plate, Transmission	Plate, 9’ x 2.75”	KITBOT-TRAN-MNT	2
	IF36	Chassis Stiffener	Angle Bracket, 6”	KITBOT-STIFFENER	4
	IF37	Hardware Kit	Misc Hardware	KITBOT-2005-HDWR	1

INNOVATION FIRST, INC. ITEM 3

<i>MOTOR KIT</i>				FRC-KIT-MOTOR-001	
	Pix	Part Name	Description	Part Number	Qty
	IF41	Motor (Large)	Motor	FP801-005	2
	IF21	Bearing, Timken	Skyway Wheel Bearing	S3KDD	8
	N/A	Screw Kit (contains 4 each - 8/32" flat head screws)	Hardware for mounting Gear tooth sensor.	JSU-229	1

INNOVATION FIRST, INC. ITEM 4 BOX UPC: 356

<i>DRIVE KIT</i>				FRC-KIT-DRIVE-001	
	Pix	Part Name	Description	Part Number *	Qty
	IF66	Output Sprocket	Output Sprocket	FRC-2005-112-009	2
	IF65	Wheel Sprocket	Wheel Sprocket	FRC-2005-120-01	2
	IF614	Hardware Pack	Hardware Pack	Hardware-TranPk-01	1
	N/A	Hardware Pack	Hardware Pack	Hardware-TranPk-02	1
	IF64	Cover	Cover	FRC-2005-112-002	2
	IF613	Hex Cluster Shaft	Hex Cluster Shaft	FRC-2005-112-003	2
	IF612	Hex Output Shaft	Hex Output Shaft	FRC-2005-112-004	2
	IF69	Hex Shaft Cluster Gear	Hex Shaft Cluster Gear	FRC-2005-112-005	2
	IF610	Small Hex shaft Gear	Small Hex shaft Gear	FRC-2005-112-006	2
	IF68	CIM Motor Input Gear	CIM Motor Input Gear	FRC-2005-111-007	4
	IF611	Large Hex Shaft Output Gear	Large Hex Shaft Output Gear	FRC-2005-112-008	2
	IF64	Transmission Housing	Transmission Housing	FRC-2005-112-001	2
	IF63	Master Link, Chain	# 35 Link	ROBOT-MLINK-35	1
	IF62	Chain, 10'	Browning # 35	ROBOT-CHAIN-35-10	1
	IF22	Bearing, Transmission- 39KDD		39KDD	6
	IF23	Bearing, Transmission-9103KDD		9103KDD	2

- - Reference: 2005 FIRST Robotics Competition Kit Transmission Manual

5.4.2.4 Kickoff Supplied Materials

<i>KICKOFF MATERIALS</i>					
	Pix	Part Name	Description	Part Number	Qty
	N/A	Google Digital Camera	Shipped to Kick-off site		1
	IF118	Battery Charger for 7.2V Battery	7.2V NiCad Charger	CHARGER-7.2	1

5.4.3 Replacement Parts Requests

After receiving your Kit of Parts (KOP), *FIRST* will be using a similar system as implemented last year for teams to submit a "Replacement Parts Request" within a short period of time after the kickoff. Any parts requested will be sent to teams via this online request system only. The Replacement Parts Request link will be posted on the Team Information Management System (TIMS) at http://www.usfirst.org/robotics/res_art2.htm after the Kickoff event.

To begin the process of submitting a Replacement Parts Request (after the kickoff), teams will:

- Log into TIMS with your Logon ID and Password;
- Click on the "Submit a Replacement Parts Request" link on right side of the Team Summary page;
- Follow TIMS instructions to complete a Replacement Parts Request

****IMPORTANT****

Please remember there is a "**one time only**" chance for submitting your Replacement Parts Request. Please be very careful to make sure your request is both accurate and complete prior to pressing the "Submit Request" button. Once the request is submitted there can be no changes to it. Please note that the system will not allow teams to request a quantity of parts higher than the number originally sent with the kit. This system is also not to be used to order additional and or purchased parts.

Replacement Parts Requests will be processed daily and items will be shipped to teams during the next open shipping window. Please remember that all requests must be placed by **11:59 pm (Eastern Time) on Wednesday, January 11, 2006.**

5.4.4 Innovation First Kit of Parts:

To submit a Replacement Parts Request for your IFI supplied kit items or for product support (to obtain a Return Merchandise Authorization Number (RMA#) prior to the return of warranted IFI parts, please contact Innovation First at 903-453-0802. Do **not** contact *FIRST* for replacements or repairs of these items.

5.4.5 Obtaining Replacement or Spare Parts:

We will have a listing of the LIMITED set of parts that will be available at events posted on the *FIRST* web site no later than January 17, 2006. If your robot is using parts not included on this list, and there is a reasonable possibility the part could be damaged or broken during competition, it is *STRONGLY RECOMMENDED* that you obtain and bring the appropriate SPARE PARTS to events.

Innovation First Inc is also hosting the *FIRST* Store on behalf of *FIRST* on the Innovation First web site. Its purpose is to assist teams with the ability to procure excess Kit of Parts items from *FIRST*. Only *FIRST* teams will be authorized to purchase the listed parts. *FIRST* will establish pricing for all parts, which will be inclusive of handling charges, but will be exclusive of shipping charges.

Additional parts and spare Innovation First parts are available and may be purchased by visiting the [IFI Store at http://www.ifirobotics.com/](http://www.ifirobotics.com/) The Innovation First, Inc. contact for *FIRST* Store matters is Tom Watson at 903-453-0800 : extension 204.

5.4.6 FIRST Loan policy for Control System Components:

Teams are responsible for all Innovation First products required at events. If at any event a team needs to borrow any part of a Control System, the team must provide a Credit Card number to ensure proper return of the items immediately upon completion of the event.

If the part is not returned at the end of the event, *FIRST* retains the right to bill the provided credit card number for the borrowed items.

All "loan" items will be available on a first-come, first-served basis.